

# ASSEMBLY INSTRUCTION

MODEL : IQ182GR GUARD RAIL

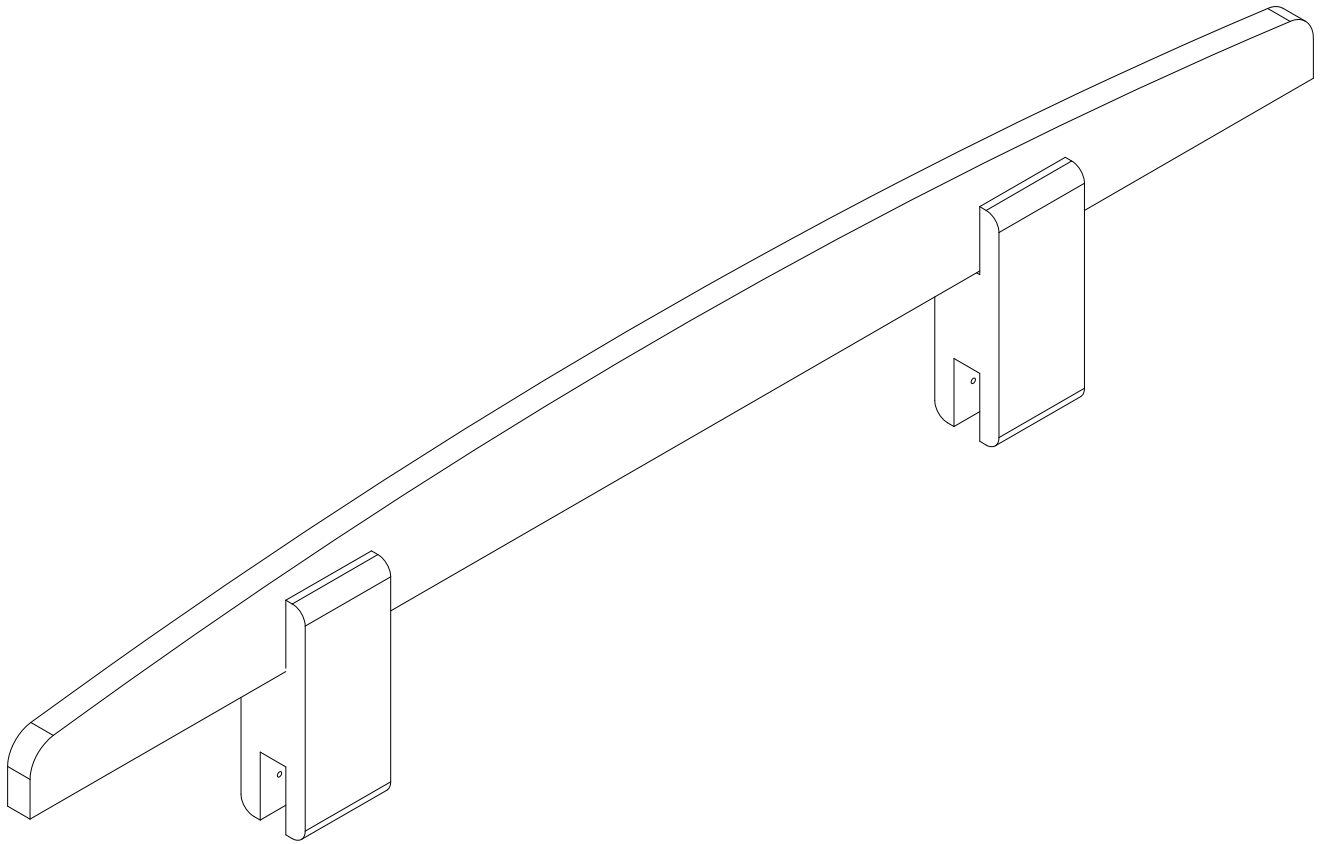

## **⚠ WARNING : SUFFOCATION AND STRANGULATION HAZARD**

- NEVER use with children younger than 3 years old. Use ONLY with older children who can get in and out of single bed without help. NEVER use in place of BABY COT.
- Gaps in and around guard rails have entrapped young children and killed infants.
- NEVER use guard rail without properly securing guard rail to bed. Incorrect installation can allow guard rail to move away from bed, which can lead to entrapment and death.
- NEVER use on toddler bed, bunk bed, water bed or bed with inflatable mattress. Use ONLY on single bed or adult bed.
- Discontinue use if damaged, broken or if parts are missing. Periodically check the guard rail for tightness to ensure guard rail is securely fasten.

### **HARDWARE LIST**

**A**

**8 PCS**



CSK RATTAN SCREW (#8 x 25MM)



*Do not recommend the use of power drills/drivers for inserting bolts/screws as this could damage the unit.*

**Tools Required :**  
**Crosshead Screw Driver**

### **PART LIST**

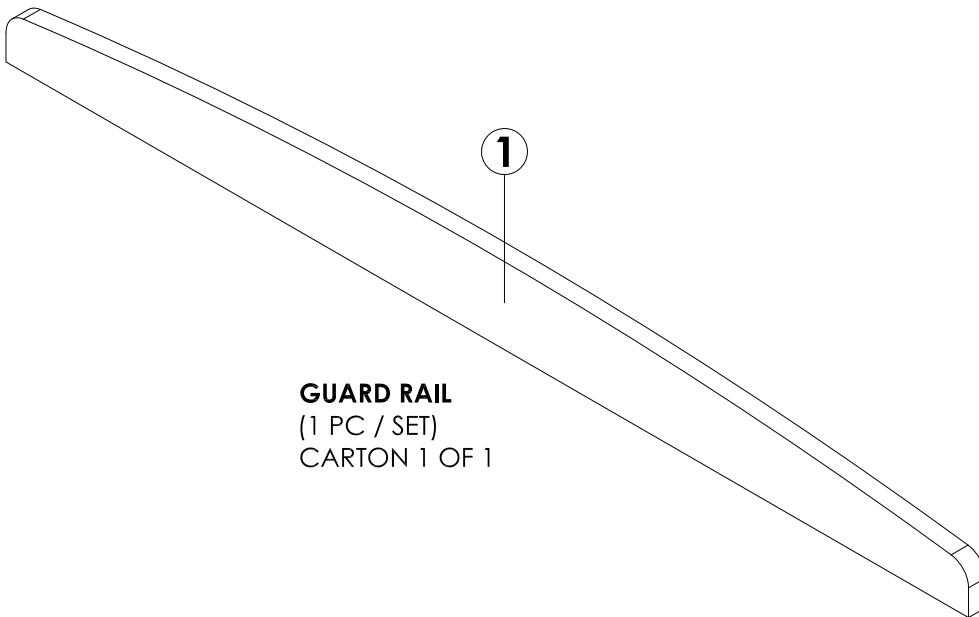

**GUARD RAIL**  
(1 PC / SET)  
CARTON 1 OF 1

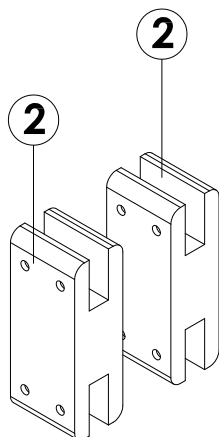

**RAIL SUPPORT**  
(2 PCS / SET)  
CARTON 1 OF 1

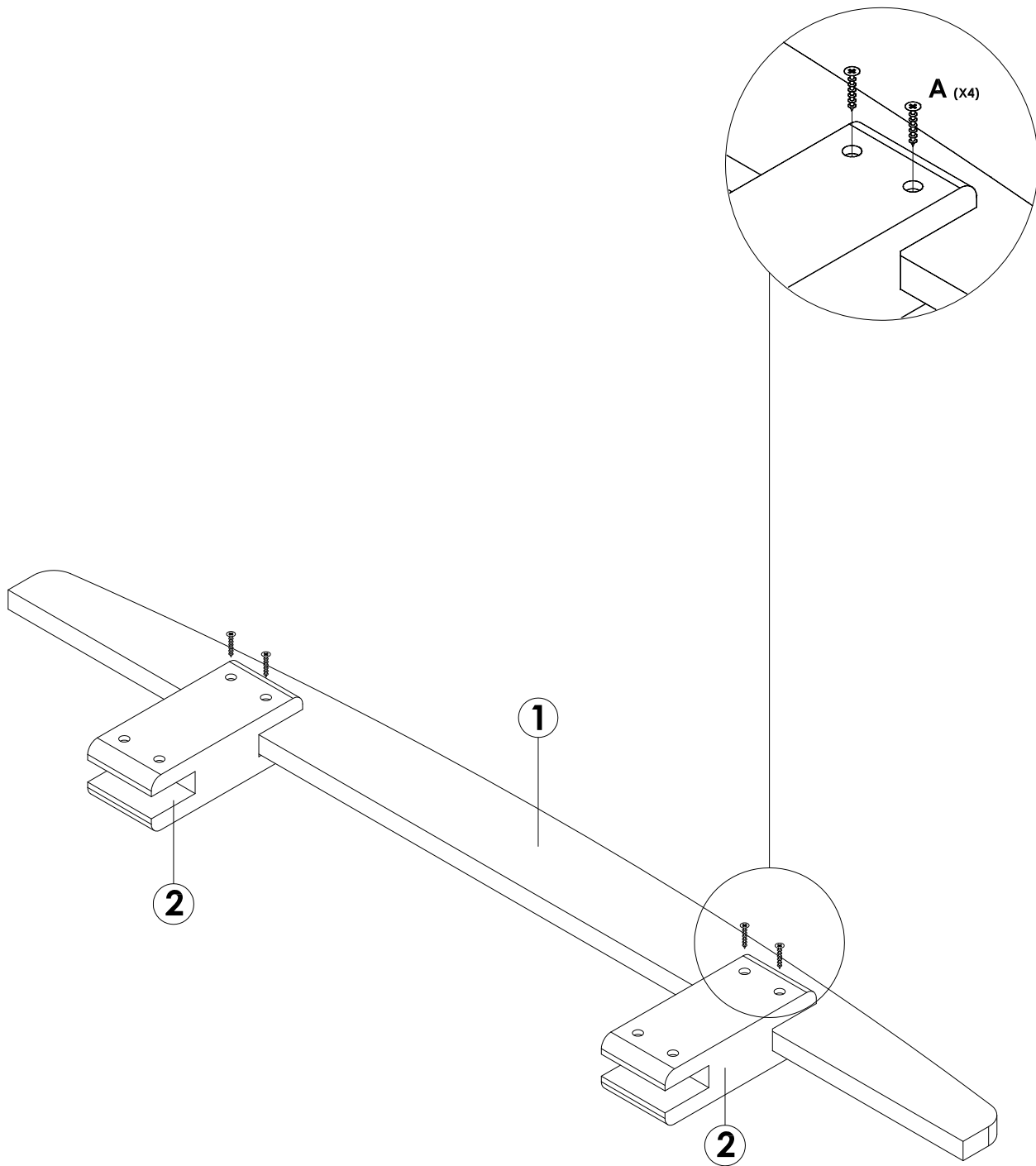

**STEP 1**

Attach and secure **Guard Rail** onto **Rail Support** by using **(A)**, tighten it up by using a Crosshead Screw Driver.

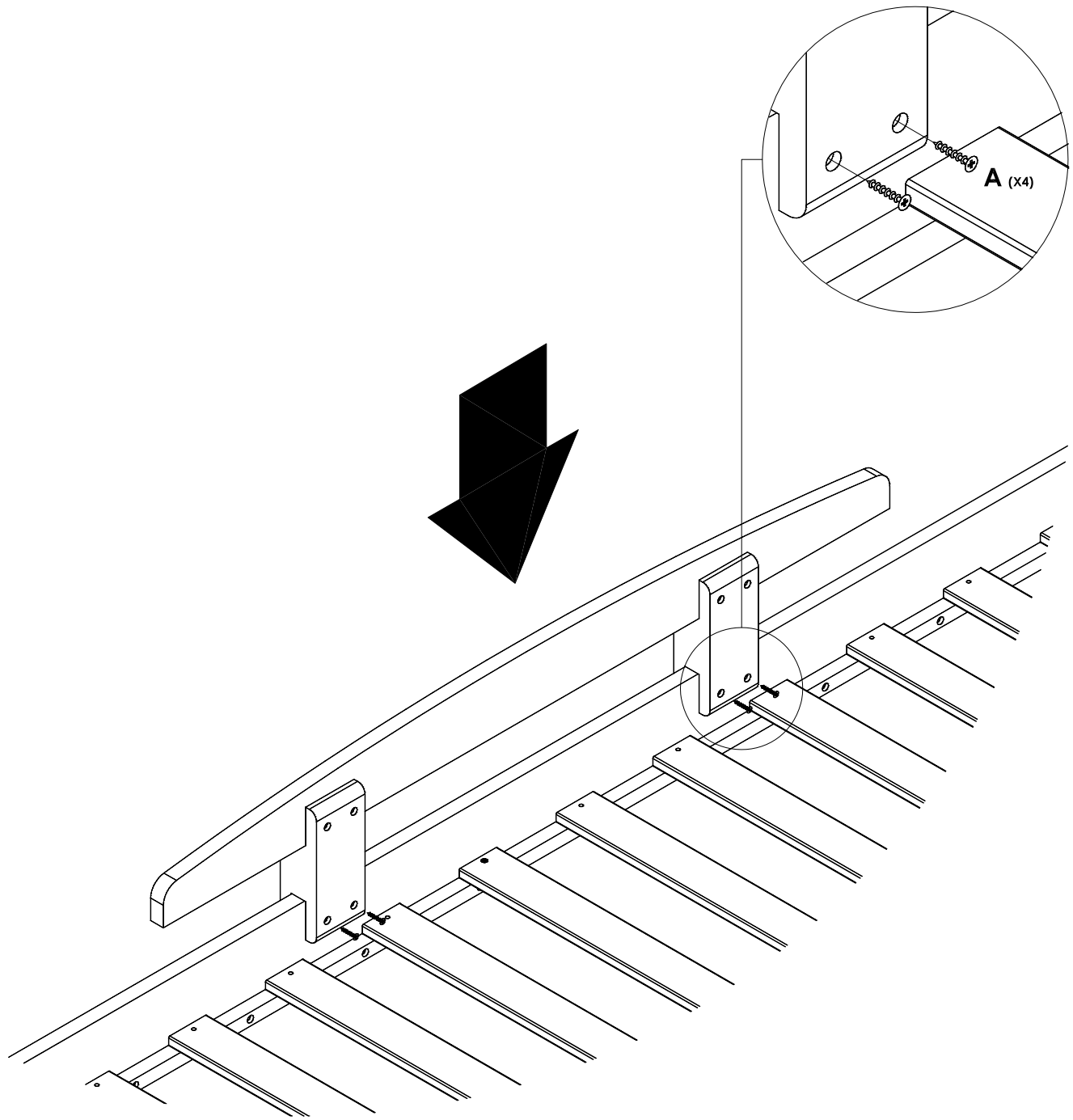

## **STEP 2**

Attach **Guard Rail** to **Side Rail** of **IQ16111W** Bed Frame by using self tapping screws (**A**), tighten up by using Crosshead Screw Driver. Not required to predrill the holes. Go on to complete the assembly.